

SDC-5330 / 5340 / 5360
Programmable DC-DC Converter with Battery Charger function

USER'S MANUAL

1. INTRODUCTION

This MCU controlled Step Down DC-DC Converter has a digitally adjustable output in 0.2V increments. It can also be set up as a Two Stage Battery Charger. Output voltage and current is displayed in the LED in turn or selectively as desired. 8 fault codes can be shown in LED for different fault diagnosis.

Intended Applications

- * Ideal for voltage sensitive loads, devices and equipment near or far from DC source.
- * Remote Automatic or Manual On/ Off Control of output makes it ideal for various DC power and DC management applications.
- * Suitable for on-board charging of stand alone 12V Battery Bank or Battery with load.

2. FEATURES

1. Digitally adjustable 0.2 V step of output voltage (12V-15V DC) makes it ideal for voltage sensitive devices.
2. 2 stage Battery Charger mode with 14.3V Bulk and 13.6V Float charge.
3. 3 digit LED display for Voltage, Current, Operation Mode and Protection/ Fault Diagnosis.
4. Remote Control Terminal for Manual or Automatic on /off of output voltage.
5. Remote Voltage Sensing for optimal and accurate powering of distant load or charging battery.
6. Remote alarm terminal (13.5V, 0.25A) for powering external warning device when input is under 19V.
7. A separate always-on auxiliary output (13.5V, 0.5A) to power critical electronic devices such as security device or remote On Off manual switch.
8. fail-save protection, with 7 self-recoverable and all with fault code on LED Display.
9. Thermostatic control cooling fan.

3. CAUTION

1. When an inductive load such as motor, solenoid is used, a diode (400V, 3Amp) must be installed across the load as shown in (Connection Diagram 1) to protect the converter from the high voltage spike generated by the load when the supplied current is switched OFF.
2. When the fuse is blown, find out and fix the problem and replace the fuse with the same type and rating.
3. Avoid touching the heat sink during operation as it may burn your hand.

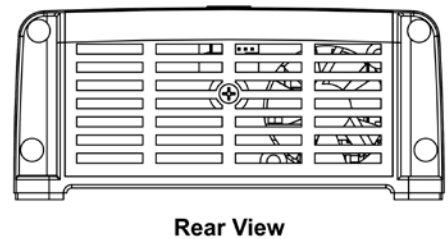
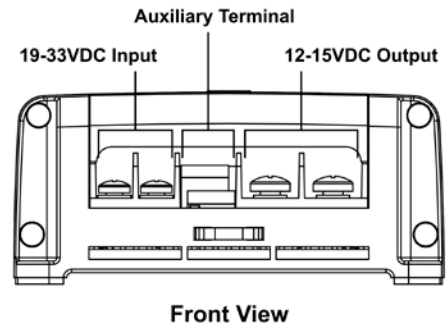
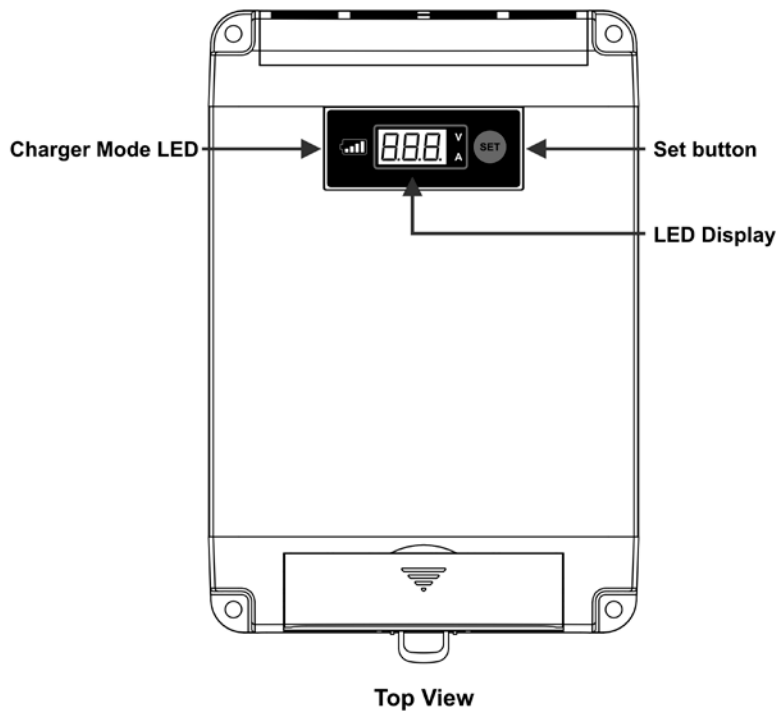

4. PANEL VIEW

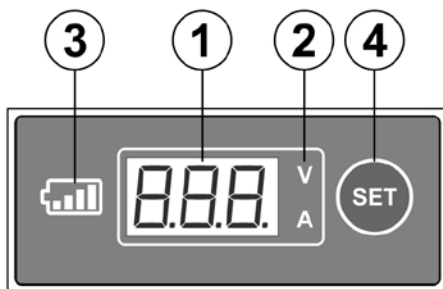

1. 3 digit LED. Displays voltage, current, operation and fault code.
2. LED indicates Voltage (V) and Current (A).
3. Battery Icon is on when converter is set at the charger mode.
4. Set button.

5. INPUT, OUTPUT, CONTROL & AUXILIARY TERMINALS VIEW

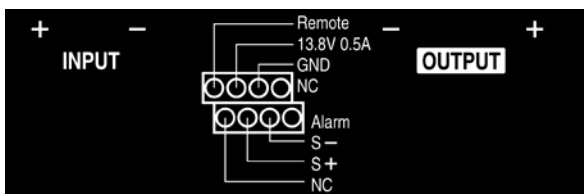

- Remote** Remote Terminal for Automatic / Manual control of Output On-Off
- 13.8V 0.5A** Always On Auxiliary Output
- GND** Ground terminal
- NC** No connection, a dummy terminal
- Alarm** Alarm for low input voltage by DC +13.5V and 0.25A to power warning device (LED)
- S+ S-** Voltage Remote Sensing positive and negative terminals,

6. Wiring Diagram

6.1 Connection Diagram 1

Example 1

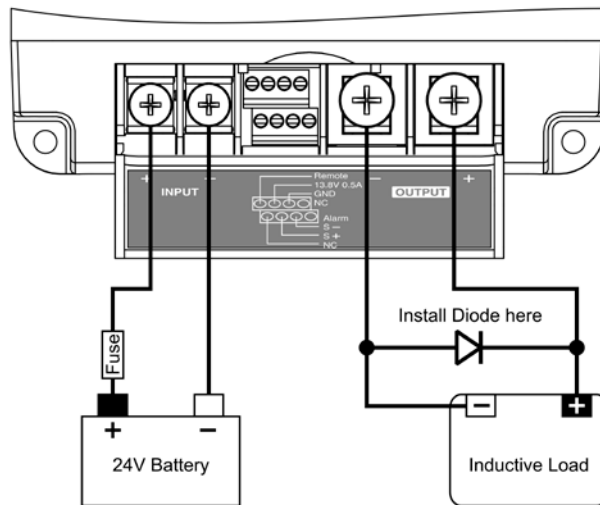

Example 2

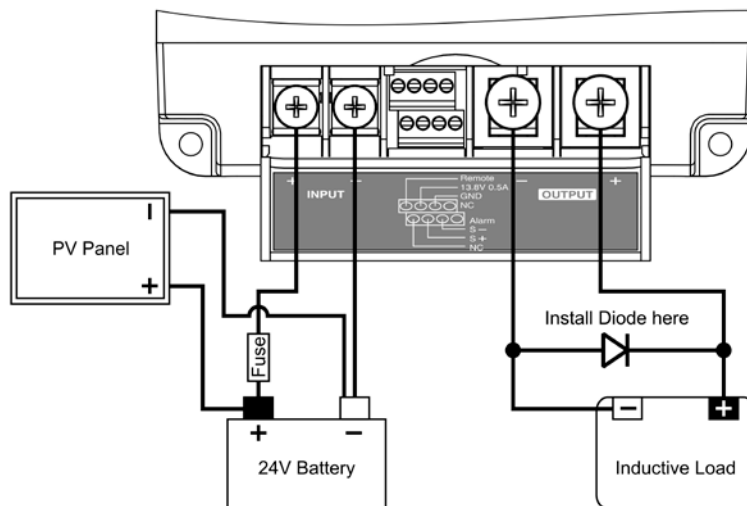

Example 3

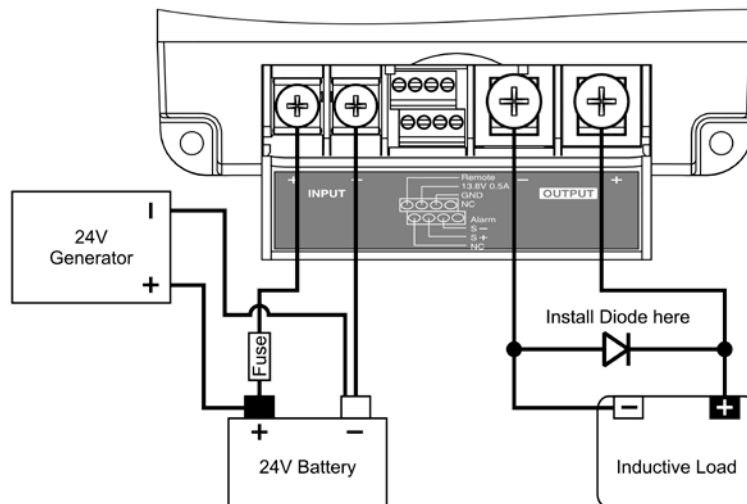

6.2 Connection Diagram 2 (Negative Ground)

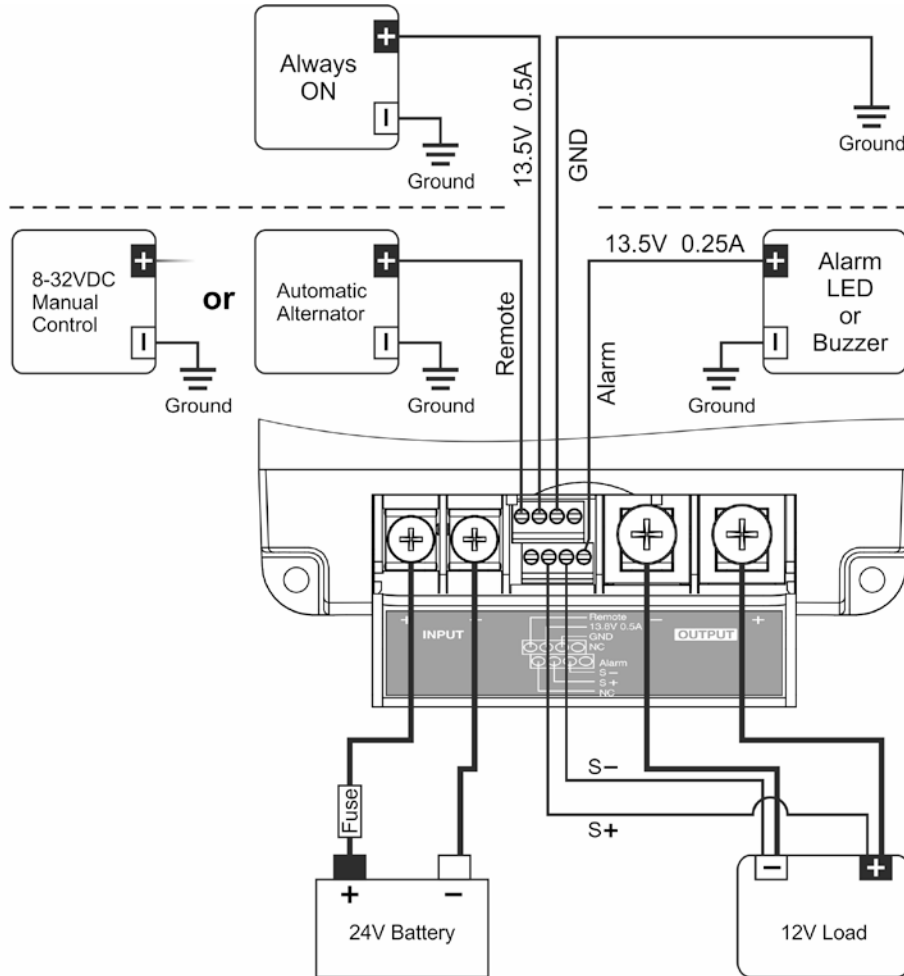

7. INITIAL SET UP AND CONNECTION

1. Leave the output terminals disconnected.
2. Connect a 24V battery to input terminals.
DOUBLE CHECK FOR CORRECT POLARITY BEFORE CONNECTION.
3. Programming Procedure using the SET button **SEL**.
4. Press and hold the "SET" button until shows up and display flashes.
5. Flashing digits indicate unit is in programmable mode.
Otherwise repeat step 4 to get to programmable mode again.
6. Each short press will increase the output voltage setting by 0.2V step..-> 15.0V -> CHA (Charger Mode).
And then back to 12.0V as shown in the following cycle chart.

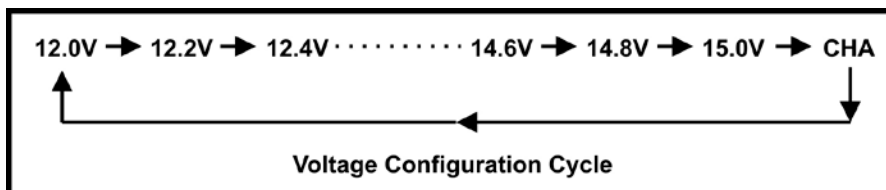

6. Stop at the desired Output Voltage or at the **CHA** if you select to set to battery charger mode.
7. After a few seconds, the display stops flashing to confirm the selected **new** setting confirmed and the unit will operate in the new set output voltage or as a battery charger.
8. Now you can connect the output terminal to a 12V device or a 12V battery according to your set mode.
Always double check for correct polarity.

8. REMOTE TERMINAL FOR AUTOMATIC / MANUAL OUTPUT On-Off CONTROL

1. The converter is set to Output always on by default at the factory.
2. Application of the Remote Control Terminal:
 - A. The converter can be set to manual control of Output On-Off via external toggle switch

Manual ON / OFF with Always ON 13.5V Output

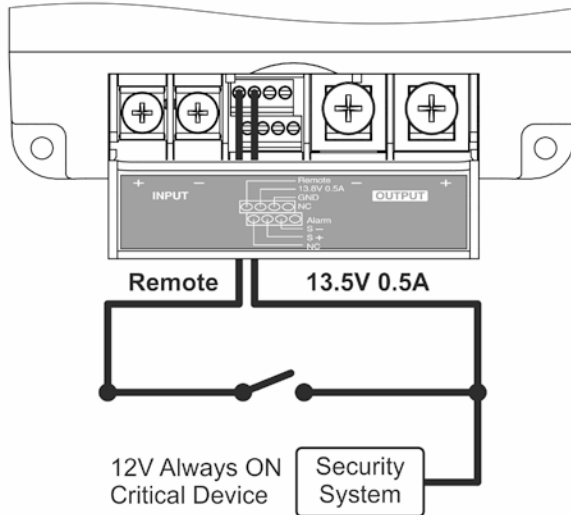

- B. The converter can be set to automatic control of Output On-off via the Ignition Switch DC source.

Remote ON / OFF with Ignition Switch

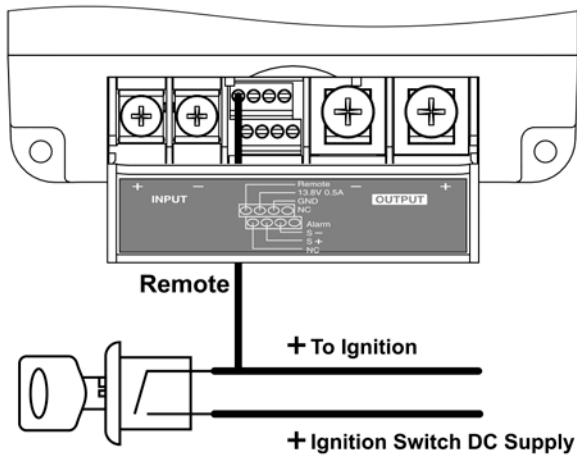

- C. The remote on off function can be controlled via many types of on-off switches with various DC source of positive 8V-32V.

Remote ON / OFF using Always ON 13.5V Output

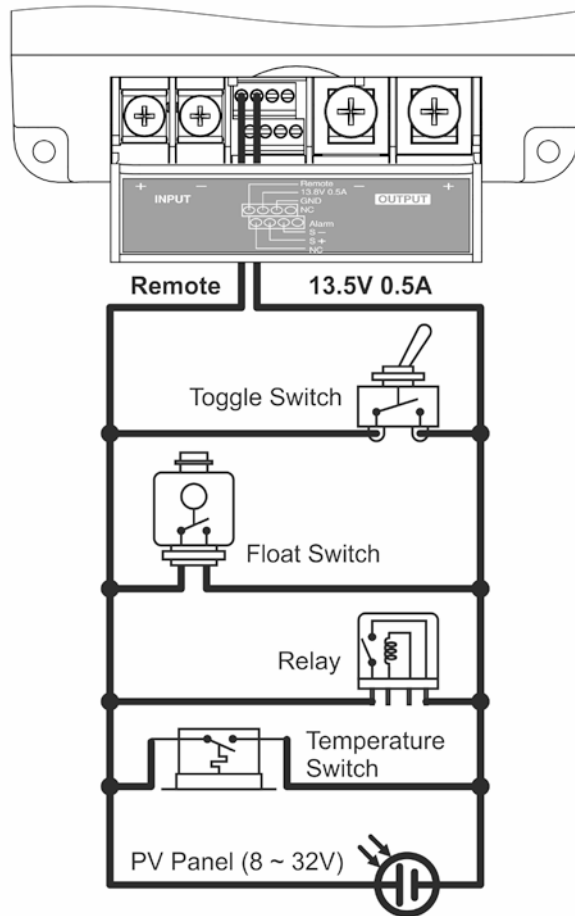

3. Once the Remote Terminal has been connected to a positive 8-32V, the converter will be modified to Remote Control Mode and will remain in this Remote Control Mode until it is disabled either by reset `RES`, or to factory preset `FLY` see section 11 and 12 for more detail information.

9. GENERAL OPERATION

LED Display

During operation, the LED display shows voltage and amps in turn. Quick press of the button will either freeze the display (at desired V, A) or return to the default scrolling mode. The display will switch off after 5 minutes to conserve energy. It can be restarted again by a quick press of the button.

When the output current is less than 1 Amp or output is open circuited the LED display will show **LOA** indicating Low Output Amp. This applies to both converter and charger mode.

In the charger mode when the output float voltage is 13.6V and the current to the battery is less than 1 Amp, can be interpreted that the Battery is Full. In the converter mode means that there is less than 1 Amp or no load drawing from the output or that the output is open circuit.

Remote Voltage Sensing

Voltage converter it can be finely tuned to supply your device the required voltage even when your device is at a distance, you can use the remote voltage sensing terminal (S-, S+) to ensure accurate point of load voltage to further improves the stability of the load point voltage.

Alarm Terminal

Alarm terminal is for input low voltage alert (F05) which provides 13.5V, 0.25A to remote LED to give out alert before the converter enters into low voltage protection mode and shuts down. The alarm signal will be On once the input is below 21V and will be Off when the input rises back above 25V.

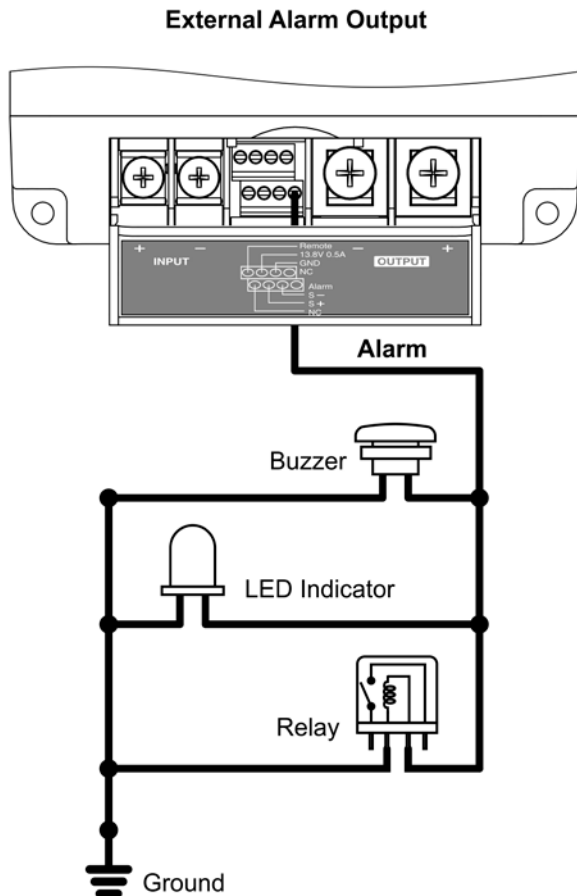

10. BATTERY CHARGER MODE - TWO STAGE CHARGER

Charging Profile

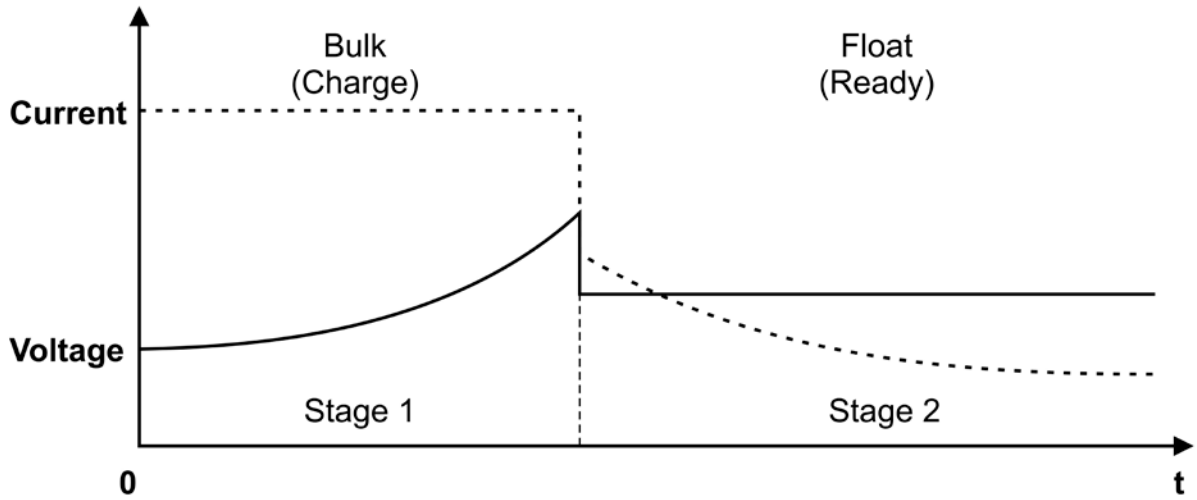





When the unit is set at the Charger Mode, LED Display **CHA**, the charger icon  will be lit up to confirm the Charger Mode in operation.

The Bulk Charge with constant current max set at 30A/40A and max voltage to 14.3V and the Float Charge voltage is at 13.6V.

The Charger Icon flashes in Bulk Charge and becomes constant in Float Charge. Quick press to Set Button will display charging voltage and current. Please note that when the battery is full and the float charge current is less than 1A, the current display shows **L0A**

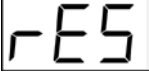
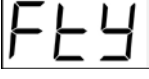
11. DISPLAY INDICATION

	Low Current Display when the output current is less than 1 Amp
	CHARGER Mode
	SELECTION (programmable) Mode, ready for programming of output voltage & charger mode
	REMOTE CONTROL DISABLED, there is always output when input is powered up
	FACTORY DEFAULT SETTINGS ENABLED (see section 12 for default settings)
	Flashing = Bulk Charge, Solid = Float Charge

12. TO ACTIVATE AND DEACTIVATE REMOTE CONTROL MODE

The Remote control terminal is disabled by default at the factory and output is always on.

To enable Remote control mode, just apply a positive 8 to 32Vdc I to Remote terminal. After remote control mode has been enabled once, it will stay enabled until it is disabled or reset to factory default setting in 12.

To disable remote control mode

- Press and hold "SET" button until **RES** is shown.
- Release button then wait for few seconds. The remote control will be disabled & output becomes always ON.

13. FACTORY DEFAULT SETTINGS

1. Unit is in DC-DC Converter Mode with Output Voltage set at 13.6V
2. Remote Control is disabled and the Output is always ON.
You can reset converter to factory default setting by following steps.

- Press and hold "SET" button until **FtY** is shown.
- Release button then wait for few seconds. The converter is reset back to factory default setting.

14. DISPLAY ON/OFF

The display will be switched off automatically after 5 minutes. Press the Set Button to restart the display for another 5 minutes.

15. ALWAYS ON AUXILIARY OUTPUT

The DC-DC converter will provide constant 13.5V, 0.5A to power critical devices such as security, alarm and also a positive voltage source for manual remote on off control of the output. Upon connection of input to 24V battery supply, the 13.5V terminal will be powered.

16. REMOTE VOLTAGE SENSING PORTS

The remote voltage sensing works for both converter mode and charger mode. It compensates for voltage drop at distant load or auxiliary battery.

It further enhances the accuracy of output voltage to the distant load or battery and provides more stability with varying output current.

Just connect AWG 22 cable between the Positive S+ to Positive of load / battery and Negative S- to Negative of load/ battery.

17. ALARM -- The low input voltage pre-warning

The alarm signal port provides a 13.5V 0.25A for external LED or other alarm device to give pre-warning signal when input voltage drops below 21V before further dropping to 19V at which output shuts down.

18. LOW CURRENT DISPLAY

The display will show **LDA** when the output current is less than 1Amp.

The converter can be in converter or charger mode or when the output is open circuit.

When in charger mode, it means the battery is full.

19. Troubleshooting

If no display comes up after connection to the input, check for correct input polarity.
Disconnect all cables to the unit and check the input fuse.

The LED will display error code when the converter is in any protection mode.
The following table denotes the 8 Error Codes.

Error Code	Description	
F01	<p>Over Temperature Protection (Self-restart)</p> <p>When unit's internal temperature becomes higher than the threshold value, unit shuts down output. Unit will resume normal operation automatically once the temperature becomes normal.</p>	
F02	<p>Output Over Voltage Protection (Self-restart)</p> <p>In DC-DC Converter Mode, output shuts down when the output voltage is 15% higher than the preset voltage level. Unit will self-restart when the output voltage falls 1V below the preset level.</p> <p>In the Bulk Charge Stage of Charger Mode, the unit shuts down >16V and restarts when the voltage <15.5V. In Float Charge Stage it shuts down when voltage >15.1V and restarts at < 14.6V.</p>	
F03	<p>Over Load Protection (Self-restart)</p> <p>When the Output current is 3 Amp higher than 40A for model SDC-5340, 30A for model SDC-5330, the unit will shut down the output. The unit will self-restart once the output current falls back to unit's rated value.</p>	
F04	<p>Fan Fault (Self-restart)</p> <p>When the fan does not operate normally, the unit will shut down the output. Unit will resume normal operation once the fan fault condition has been removed.</p>	
F05	<p>Input Low Voltage Protection (Self-restart)</p>	
	Input V < 21V	Alarm signal On
	Input V > 25V	Alarm signal Off
	15V < Input V < 19V for 3 min.	Output shuts down ; self-restart > 25V
	Input V < 15V	Output instant shut down; self-restart >25V
F06	<p>Output Short Circuit Protection (Self-restart)</p> <p>Unit shuts down output when the output is short circuited. It will self-restart when the fault condition is removed.</p>	
F07	<p>Output battery terminal reverse polarity protection</p> <p>Fuse will be blown when the output is reverse polarity connected to the battery. Replace the fuse with correct type and rating.</p>	
F08	<p>Input over voltage protection (Self-restart)</p> <p>Output shuts down when the input voltage is higher than 33.5V. It will self-restart when the input drops below 32V.</p>	

20. SPECIFICATIONS

Models	SDC-5330	SDC-5340	SDC-5360
Input Voltage Range	19 – 33VDC		
Output Voltage Range	12 – 15VDC (0.2V increments)		
Continuous Output Current	30A	40A	60A
No load current	< 50mA	< 50mA	< 90mA
Efficiency	≥ 90%		
Protections	Over Voltage, Overload, Input Reverse Polarity, Over Temperature, Output Reverse Polarity, Output Short Circuit, Input Under Voltage		
Aux. Output (Always On)	13.5V / 0.5A		
Two Stage Battery Charger	Bulk Charge 14.3V Max. Constant Current 30/ 40/ 60A, Float Charge 13.6V		
Remote Control of Output ON/OFF	Yes, Automatic or Manual Control		
Remote Voltage Sense	Yes		
External Alarm Output	13.5V / 0.25A		
Indicators	3 digits LED display for V, A & Fault Indication, Battery Charger Indicator		
Cooling System	Thermostatic Control Fan		
Operating Temperature	-10°C to +50°C		
Approvals	EN 55014, EN60335.2.29		
Accessory	Supplied 4 cable lug connectors, One 400V 3A diode		
Dimensions (WxHxD)	130x55x160 mm 5.2x2.2x6.3 inch	130x55x190 mm 5.2x2.2x7.5 inch	130x55x208 mm 5.2x2.2x8.2 inch
Weight	1kg 2.2lbs	1.2kg 2.64lbs	1.3kg 2.86lbs
Recommended Battery Capacity Range	100AH to 300AH	130AH to 400AH	200AH to 600AH

REV.1 20170712
7673-5340-0581