

SDC-310 SWITCHING MODE DC-DC POWER CONVERTER

USER'S MANUAL

INTRODUCTION

SDC-310 is high quality 13.8V-28V DC-DC Power Converter primarily designed for 28V DC powering of automotive and marine electronic equipment. It is implemented by using Switching Mode Power Supply technology to make it generate less heat and hence higher efficiency. Advanced design, quality production control and sturdy construction assure continue stability and reliability.

FEATURES

1. **Overload Protection:** When the output current is being over the limitation, the overload circuitry is activated and the output voltage and current are reduced to protect the unit.
2. **Over Voltage Protection:** When the output terminal appears over the voltage output limit, the over voltage protection is activated and the output voltage is shut down to protect the unit and your equipment.
3. **High RFI Stability:** The unit is designed for high protection circuitry against RFI (Radio Frequency Interference) provides a stable operation without affected by RFI.

FRONT PANEL

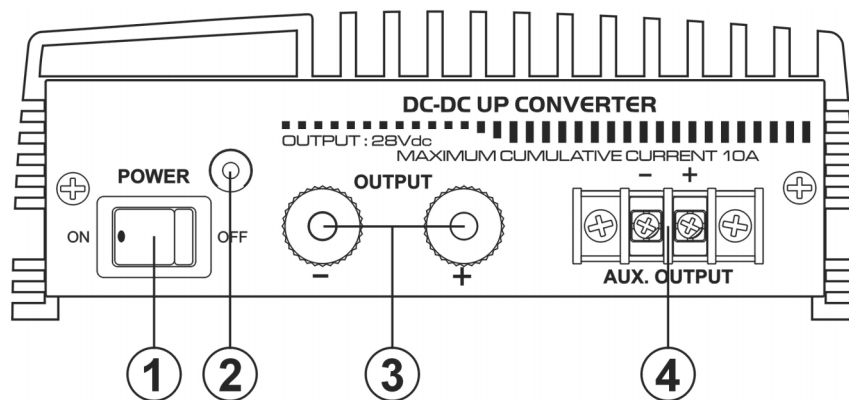

1. **POWER SWITCH:** Switch ON/OFF the unit.
2. **POWER INDICATOR:** Lights up when the unit is activated.
3. **SCREW-ON OUTPUT TERMINAL:** Full load output terminal.
4. **2-WAY TERMINAL BLOCK**

Note: *The total output current of all terminals must not exceed the output current as listed on the specifications next page.*

CAUTION

1. **DO NOT** use the unit for the equipment requires current input that higher than the designed value otherwise it may damage the unit.
2. **DO NOT** use the unit for charging battery.

3. DO NOT use the unit for lamps or motorized equipment that require high current input at starting as it may damage the unit.
4. When the fuse is broken, DO NOT replace the fuse before ceasing the problem. The value of the fuse taken in place must match the assigned value.
5. DO NOT feed the voltage other than 9.5-16V DC otherwise damage the unit. The input voltage range specified is the range of the operating voltage.
6. DO NOT switch ON the unit when it is full loaded as it may damage the unit.
7. MUST place the unit at a place of well air ventilation, heat is generated during operation.
8. NEVER touch the heat sink panel during the unit is operating. The heat sink may be heated up and burn your hand.
9. DO NOT feed a voltage source into the output terminal, it may damage the unit.
10. BE SURE wiring connections otherwise it may damage the unit. Red cable is for INPUT (+) and Black cable is for INPUT (-). Red terminal is for OUTPUT (+) and Black terminal is for OUTPUT (-).

Note: The ground (negative polarity, input and output negative polarities are common.) of the unit is connected to the case.

CONNECTION AND OPERATION

1. Switch OFF the unit.
2. Connect the Input Red Cable to positive terminal (+) and the Input Black Cable to negative terminal (-) of the 12V DC Battery (make sure the battery is not empty) firmly.
3. Turn OFF the equipment to be operated and connect the Red (+) output terminal of the unit to the positive (+) polarity input of the equipment. Connect the (-) output terminal of the unit to the negative (-) polarity input of the equipment.
4. Switch ON the unit, POWER INDICATOR lights up, then turn ON the equipment to be powered.
5. When the operation is finished, turn OFF the equipment first and then switch OFF the unit.
6. If the power indicator does not light up or becomes dimmer and the unit has no output voltage when the battery (not empty) is connected and power is ON, the unit may be under the condition of overload or over voltage. Disconnect the equipment and check the unit for working properly. If the unit work properly, check the equipment that causing the problem and DO NOT connect the equipment that causing the problem. If the unit does not work properly, send it back to your dealer for checking and repairing.

SPECIFICATIONS

OUTPUT VOLTAGE:	28V±0.5V DC
OUTPUT CURRENT:	8A
RIPPLE & NOISE (R.M.S):	10mV
LINE REGULATION:	150mV
LOAD REGULATION:	300mV
EFFICIENCY:	≥88%
OUTPUT CONNECTION:	Screw-on Terminal and 2-Way Terminal Block
OPERATION VOLTAGE:	9.5 - 16V DC
DIMENSION (W×H×D):	156 × 57 × 130 (mm)
WEIGHT:	1Kg (Approx.)